

PSk2-7 CS-F20-5

Solar Surface Pump System

System Overview

Head	max. 50 m
Flow rate	max. 33 m ³ /h

Technical Data

Controller PSk2-7

- High efficiency solar pump controller
- Hybrid power (solar / grid / generator) support with LORENTZ SmartSolution
- Inputs for water meter, pressure sensors, digital switches
- Simple configuration with LORENTZ PumpScanner Android™ App
- Onboard data logging and system monitoring
- Inbuilt applications for constant pressure, constant flow and daily amount
- Integrated Sun Sensor
- Active temperature management
- Integrated MPPT (Maximum Power Point Tracking)

Power	max. 8,0 kW
Input voltage	max. 850 V
Optimum Vmp**	> 575 V
Motor current	max. 13 A
Efficiency	max. 98 %
Ambient temp.	-30...50 °C
Enclosure class	IP54

Motor AC DRIVE CS-F 5.5kW

- Highly efficient 3-phase AC motor
- Frequency: 25...50 Hz

Motor speed	1.400...2.850 rpm
Power factor	0,84
Insulation class	F
Enclosure class	IPX4

Pump End PE CS-F20-5

- Premium materials
- Optional: dry running protection
- Centrifugal pump

Pump Unit PUK2-7 CS-F20-5 (Motor, Pump End)

Water temperature	max. 70 °C
Suction head	acc. to COMPASS sizing

Standards



2006/42/EC, 2004/108/EC, 2006/95/EC

IEC/EN 61702:1995, IEC/EN 62253 Ed.1

The logos shown reflect the approvals that have been granted for this product family. Products are ordered and supplied with the approvals specific to the market requirements.

**Vmp: MPP-voltage under Standard Test Conditions (STC): 1000 W/m² solar irradiance, 25 °C cell temperature



PSk2-7 CS-F20-5

Solar Surface Pump System

Pump Chart

Vmp* > 575 V

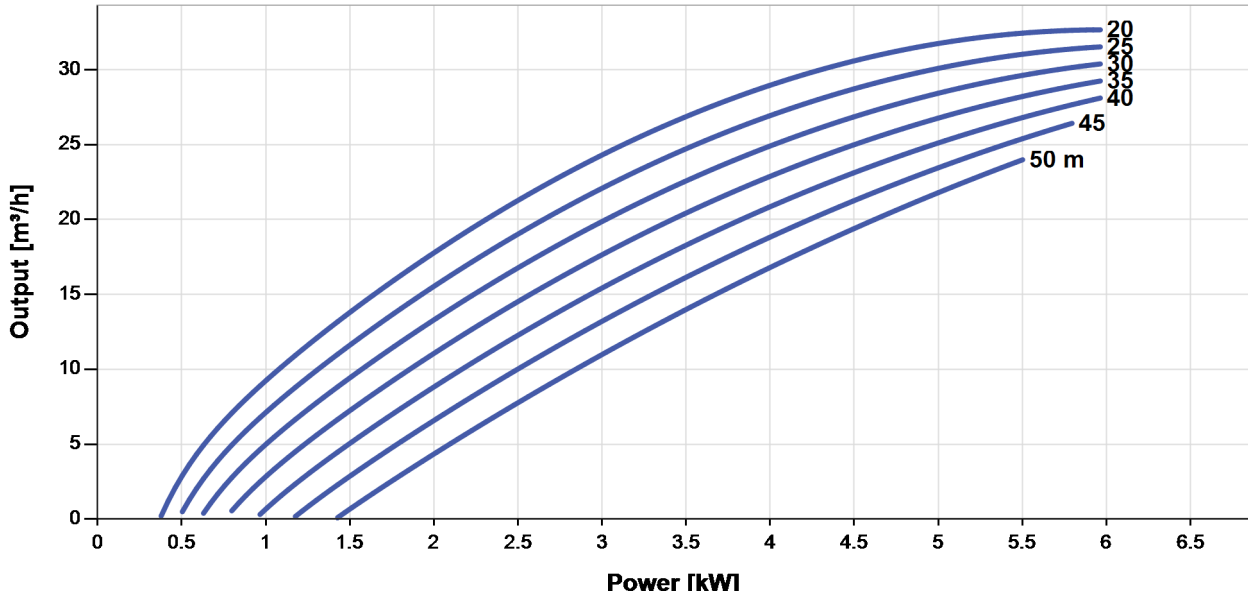

NPSH

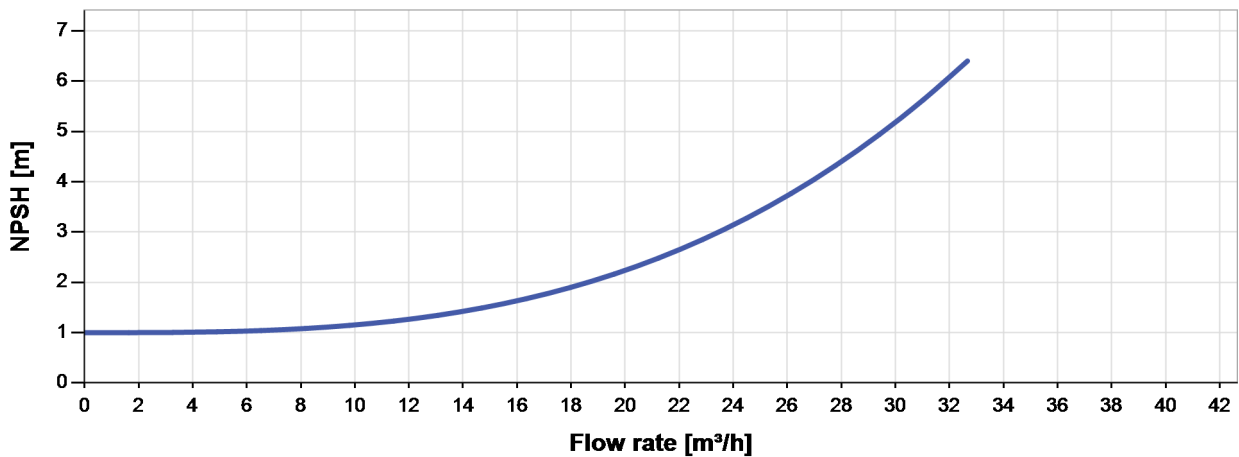

The NPSH (Net Positive Suction Head) is NOT the operating suction head. To calculate the operating suction head please refer to the installation manual.

*Vmp: MPP-voltage under Standard Test Conditions (STC): 1000 W/m² solar irradiance, 25 °C cell temperature



PSk2-7 CS-F20-5

Solar Surface Pump System

Dimensions and Weights

Controller

H = 500 mm
 H1 = 450 mm
 H2 = 421 mm
 W1 = 320 mm
 W2 = 290 mm
 D = 9,0 mm
 D1 = 226 mm

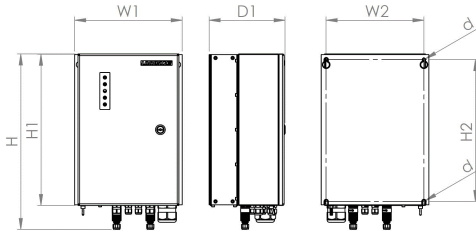

Pump Unit

A = 260 mm
 B = 208 mm
 C = 430 mm
 D = 300 mm
 E = 199 mm
 F = 130 mm
 G = 90 mm
 H = 562 mm
 I = G1/2"
 J = 247 mm
 K = 215 mm
 L = 50 mm
 M = 125 mm
 N = 18 mm
 O = 35 mm
 P = 14 mm

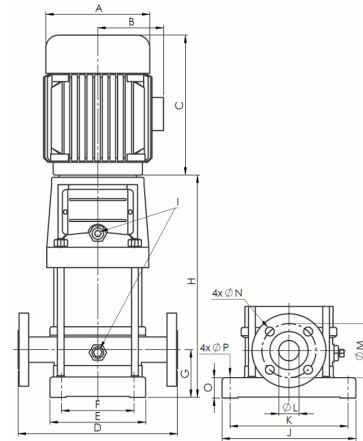

	Net weight
Controller	18 kg
Pump Unit	76 kg
Motor	59 kg
Pump End	17 kg

