

# PSk2-15 CS-G100-27/2

## Solar Surface Pump System

### System Overview

Head	max. 25 m
Flow rate	max. 135 m³/h

### Technical Data

#### Controller PSk2-15

- High efficiency solar pump controller
- Hybrid power (solar / grid / generator) support with LORENTZ SmartSolution
- Inputs for water meter, pressure sensors, digital switches
- Simple configuration with LORENTZ PumpScanner Android™ App
- Onboard data logging and system monitoring
- Inbuilt applications for constant pressure, constant flow and daily amount
- Integrated Sun Sensor
- Active temperature management
- Integrated MPPT (Maximum Power Point Tracking)

Power	max. 15 kW
Input voltage	max. 850 V
Optimum Vmp**	> 575 V
Motor current	max. 24 A
Efficiency	max. 98 %
Ambient temp.	-30...50 °C
Enclosure class	IP54

#### Motor AC DRIVE CS-G 11kW

- Highly efficient 3-phase AC motor
- Frequency: 25...51 Hz

Motor speed	1.400...2.905 rpm
Power factor	0,87
Insulation class	F
Enclosure class	IPX4

#### Pump End PE CS-G100-27/2

- Premium materials
- Optional: dry running protection
- Centrifugal pump

#### Pump Unit PUK2-15 CS-G100-27/2 (Motor, Pump End)

Water temperature	max. 90 °C
Suction head	acc. to COMPASS sizing

### Standards



2006/42/EC, 2004/108/EC, 2006/95/EC

IEC/EN 61702:1995, IEC/EN 62253 Ed.1

The logos shown reflect the approvals that have been granted for this product family. Products are ordered and supplied with the approvals specific to the market requirements.

\*\*Vmp: MPP-voltage under Standard Test Conditions (STC): 1000 W/m² solar irradiance, 25 °C cell temperature



## PSk2-15 CS-G100-27/2

### Solar Surface Pump System

#### Pump Chart

Vmp\* > 575 V

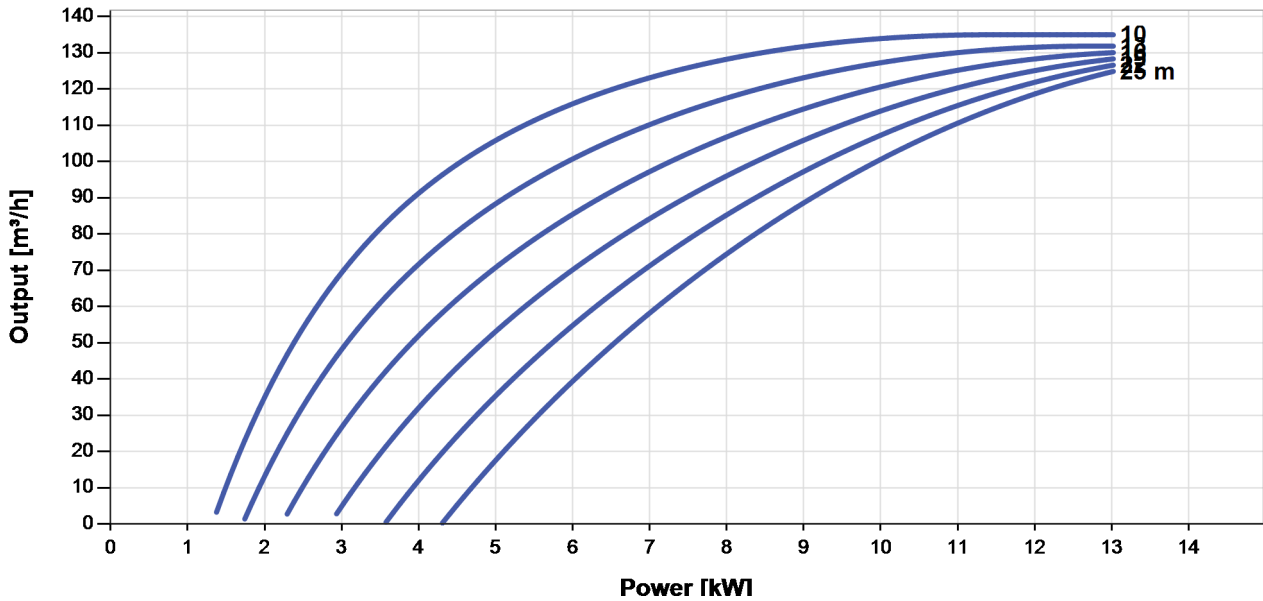

#### NPSH

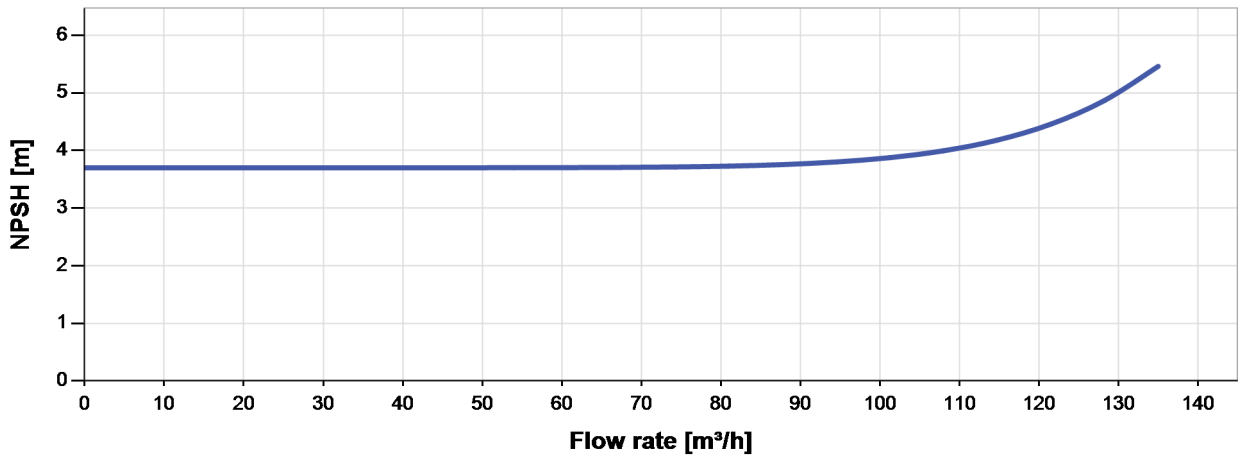

The NPSH (Net Positive Suction Head) is NOT the operating suction head. To calculate the operating suction head please refer to the installation manual.

\*Vmp: MPP-voltage under Standard Test Conditions (STC): 1000 W/m² solar irradiance, 25 °C cell temperature



## PSk2-15 CS-G100-27/2

### Solar Surface Pump System

#### Dimensions and Weights

##### Controller

H = 500 mm  
 H1 = 450 mm  
 H2 = 421 mm  
 W1 = 320 mm  
 W2 = 290 mm  
 D = 9,0 mm  
 D1 = 226 mm

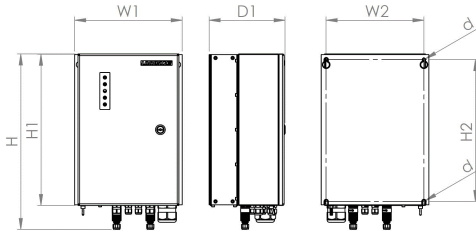

##### Pump Unit

A = 350 mm  
 B = 245 mm  
 C = 490 mm  
 D = 550 mm  
 E = 140 mm  
 F = 260 mm  
 G = 147 mm  
 H = 123 mm  
 I = 100 mm  
 J = 156 mm  
 K = 180 mm  
 L = 220 mm  
 M = 18 mm  
 N = 350 mm  
 O = 144 mm  
 P = M16  
 Q = 235 mm  
 R = 195 mm  
 S = 144 mm  
 T = 14 mm  
 U = 18 mm  
 V = 120 mm  
 W = 160 mm  
 X = 35 mm

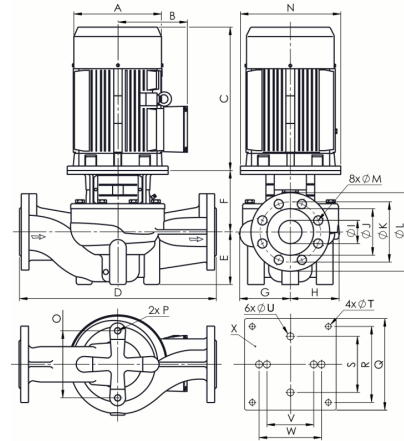

	Net weight
Controller	18 kg
Pump Unit	183 kg
Motor	107 kg
Pump End	76 kg

