

PS15k2 C-SJ17-18

Solar Submersible Pump System for 6" wells

System Overview

Head	max. 140 m
Flow rate	max. 22 m³/h

Technical Data

Controller PS15k2

- Control inputs for dry running protection, remote control etc.
- Protected against reverse polarity, overload and overtemperature
- Integrated MPPT (Maximum Power Point Tracking)

Power	max. 15 kW
Input voltage	max. 850 V
Optimum Vmp*	> 575 V
Motor current	max. 24 A
Efficiency	max. 98 %
Ambient temp.	-30...50 °C
Enclosure class	IP54

Motor AC DRIVE SUB 6" 11kW

- Highly efficient 3-phase AC motor
- Frequency: 25...50 Hz
- Premium materials, stainless steel: AISI 304
- No electronics in the motor

Motor speed	1,400...2,850 rpm
Power factor	0.87
Insulation class	F
Enclosure class	IP68
Submersion	max. 300 m

Pump End PE C-SJ17-18

- Non-return valve
- Premium materials, stainless steel: AISI 304
- Optional: dry running protection
- Centrifugal pump

Pump Unit PU C-SJ17-18 (Motor, Pump End)

Borehole diameter	min. 6,0 in
Water temperature	max. 30 °C



Standards

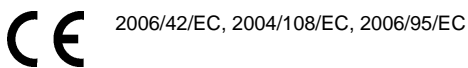

Meets the requirements of:
IEC/EN 61702:1995,
IEC/EN 62253 Ed.1

The logos shown reflect the approvals that have been granted for this product family. Products are ordered and supplied with the approvals specific to the market requirements.

*Vmp: MPP-voltage under Standard Test Conditions (STC): 1000 W/m² solar irradiance, 25 °C cell temperature



PS15k2 C-SJ17-18

Solar Submersible Pump System for 6" wells

Pump Chart

Vmp* > 575 V

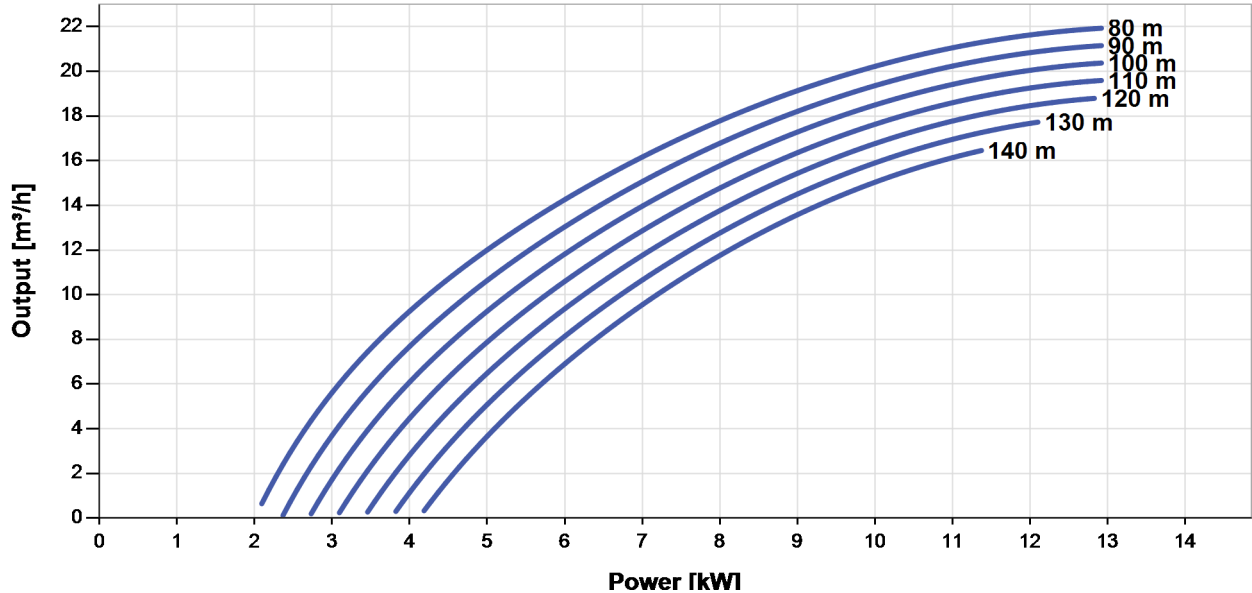

Dimensions and Weights

Controller

- H = 500 mm
- H1 = 450 mm
- H2 = 425 mm
- W1 = 320 mm
- W2 = 290 mm
- D = 9.0 mm
- D1 = 220 mm
- D2 = 250 mm

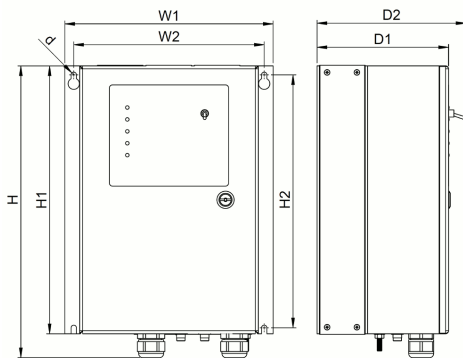

Pump Unit

- A = 2,083 mm
- B = 711 mm
- C = 1,372 mm
- D = 144 mm
- E = 133 mm
- S = 2.5 in

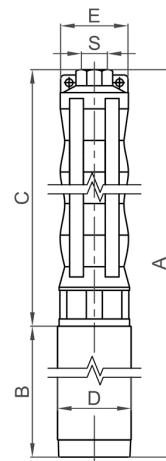

	Net weight
Controller	17 kg
Pump Unit	87 kg
Motor	58 kg
Pump End	29 kg

*Vmp: MPP-voltage under Standard Test Conditions (STC): 1000 W/m² solar irradiance, 25 °C cell temperature

