

Solar Max CPI series

Off-grid Inverter



USER MANUAL

Version 1.2

Date: Nov. 2013

About TBB

TBB Power is a dedicated designer and manufacturer of sophisticated and environmentally rugged power electronics equipment.

We are offering a wide range of power conversion product from battery charger, standalone inverter, inverter charger combination and solar charge controller.

We ensure consistent product quality by subjecting every product to strictly choice of superior quality components, rigorous testing and burn-in through out the production process. TBB Power is certified by TUV in accordance with ISO9001 and can be your reliable power solution provider.

Disclaimer

Unless specially agreed in writing, TBB Power Co.,Ltd

- Take no warranty as to the accuracy, sufficiency of suitability of any technical or other information provided in this manual or other documentation.
- Assumes no responsibility or liability for loss or damage, whether direct, indirect, consequential or incidental, which might arise out of the use of such information

About this Manual

This manual describes our product features and provides procedure of installations. This manual is for anyone intending to install our equipment.

Contact Information

TBB Power Co.,Ltd

Web: www.tbbpower.com

Tel: +86-592-5212299

Fax: +86-592-5796070

Email: service@tbbpower.com

General Instruction

Thanks for choosing our products and this manual were suitable for CPI series pure sine wave inverter.

This chapter contains important safety and operation instructions. Read and keep this User Guide well for later reference.

The CPI series needs to be installed by professionals and please pay attention to the following points prior to installation:

- 1> Please check the input voltage or voltage of battery is same to the nominal input voltage of this inverter.
- 2> Please connect positive terminal “+” of battery to “+” input of the inverter.
- 3> Please connect negative terminal “-” of battery to “-” input of the inverter.
- 4> Please use the shortest cable to connect and ensure the secure connection.
- 5> While connecting, please secure the connection and avoid short cut between positive terminal and negative terminal of battery, which will cause damage of battery.
- 6> Inverter will have high voltage inside. Only authorized electrician can open the case.
- 7> The inverter WAS NOT designed to use in any life retaining equipment.

Index

- 1.0 General Safety Instruction**
 - 1.1 Safety Instruction
 - 1.2 General Precaution
 - 1.3 Precaution regarding battery operation

- 2.0 Description**

- 3.0 Structure**

- 4.0 Setting**
 - 4.1 Low Voltage disconnect (LVD)
 - 4.2 Output Voltage and Frequency

- 5.0 Control and Communication**
 - 5.1 Dry contact
 - 5.2 RCC

- 6.0 Installation**
 - 6.1 Material List
 - 6.2 Location
 - 6.3 Wiring recommendation
 - 6.4 General Advice
 - 6.5 Installation and Connection

- 7.0 Operation**

- 8.0 Trouble Shooting**

- 9.0 Specification**

1. General Safety Instruction

1.1 Safety Instruction

As dangerous voltages and high temperature exist within the CPI, only qualified and authorized maintenance personnel are permitted to open and repair it.

This manual contains information concerning the installation and operation of the CPI. All relevant parts of the manual should be read prior to commencing the installation. Please follow the local stipulation meantime.

Any operation against safety requirement or against design, manufacture, safety standard, and are out of the manufacturer warranty.

1.2 General Precaution

- 1.2.1 Do not expose to dust, rain, snow or liquids of any type, it is designed for indoor use. DO NOT block off ventilation, otherwise the INVERTER would be overheating.
- 1.2.2 To avoid fire and electric shock, make sure all cables selected with right gauge and being connected well. Smaller diameter and broken cable are not allowed to use.
- 1.2.3 Please do not put any inflammable goods near to inverter.
- 1.2.4 Never place unit directly above batteries, gases from a battery will corrode and damage inverter/charger.
- 1.2.5 Do not place battery over inverter.

1.3 Precaution regarding battery operation

- 1.3.1. Use plenty of fresh water to clean in case battery acid contacts skin, clothing, or eyes and consult with doctor as soon as possible.
- 1.3.2. The battery may generate flammable gas during charging. NEVER smoke or allow a spark or flame in vicinity of a battery.
- 1.3.3. Do not put the metal tool on the battery, spark and short circuit might lead to explosion.
- 1.3.4. REMOVE all personal metal items such as rings, bracelets, necklaces, and watches while working with batteries. Batteries can cause short-circuit current high enough to make metal melt, and could cause severe burns.

2.0 Description

CPI is a pure sine wave inverter specially designed for solar off grid application, of which could deliver high quality power with unexpected overload capability.

- Pure Sine Wave
- Outstanding Peak Power
- High efficiency up to max 94%
- Extremely low status consumption power
- Power save mode available
- Low voltage disconnect level settable
- High temperature design
- Built in auxiliary contact for battery low alarm
- Comprehensive Protection
- Remote control available

3.0 Structure

Front Panel

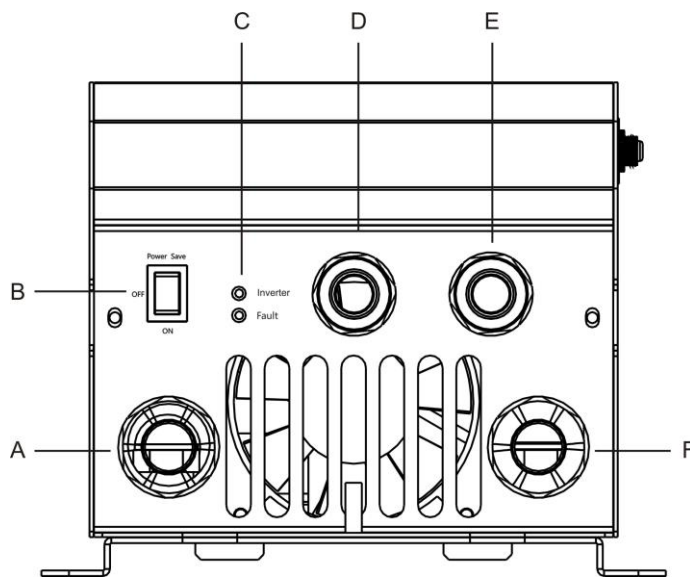

A	DC cable through hole
B	Main switch
C	LED
D	Gland for remote control cable
E	Gland for AC output
F	DC cable through hole

Side Panel

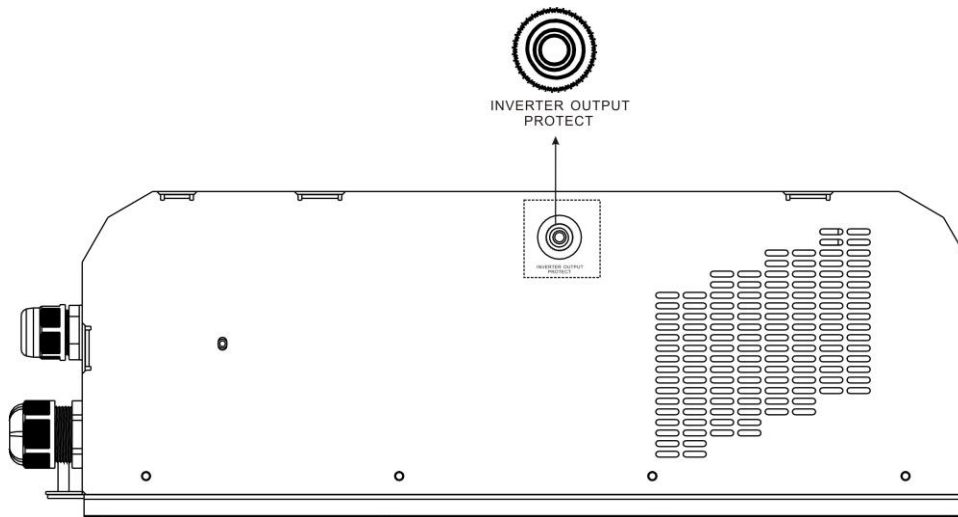

On Right side panel, there is a circuit breaker as a overload protection for inverter output.

Central Panel

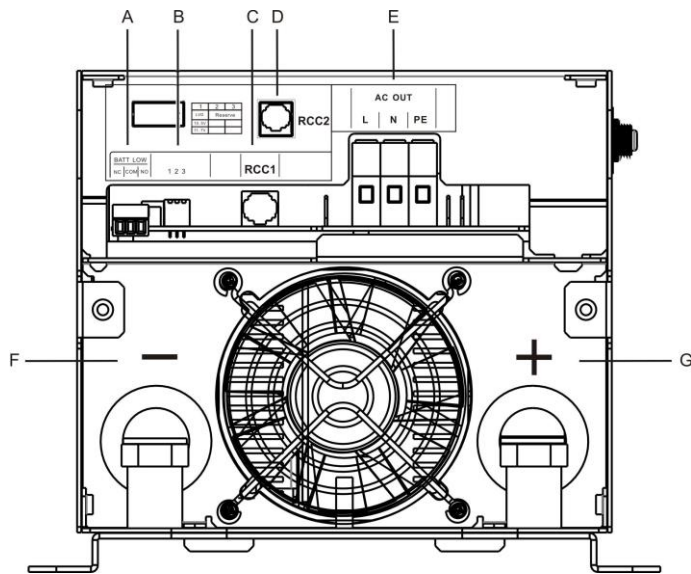

A	Dry contact (battery low)
B	Dip Switch
C	RCC panel connector
D	
E	AC output terminal
F	DC -
G	DC +

4.0 Configuration

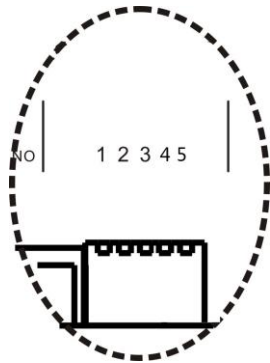

Through dipswitch at central panel, you can have some configuration of the inverter

4.1 Low Voltage disconnect (LVD)

Through the **Dip Switch 1**, you can configure the low voltage protection level for your system. Please find following data.

The following DOD is estimation **ONLY**. The exact measure of the battery SOC is almost impossible with only electrical parameter. It may vary according to discharge current, battery healthy etc.

SW1	12VDC model	24VDC model	48VDC model	est DOD	recommendation
off	11.7VDC	23.4VDC	46.8VDC	ab. 60%	solar or backup
on	10.5VDC	21VDC	42VDC	>90%	mobile

The default setting was OFF, 11.7VDC (12V model) / 23.4VDC (24V model) / 46.8VDC (48V model)

4.2 Output Voltage and Frequency Configuration

Through the **Dip Switch 2 and 3**, you can configure the output with various voltages for high voltage model (HV model) and low voltage model (LV model).

Dip Switch 2	Dip Switch 3	Output voltage of HV MODEL	Output voltage of LV MODEL
OFF	OFF	230VAC	110VAC
ON	OFF	208VAC	100VAC
OFF	ON	240VAC	127VAC
ON	ON	220VAC	120VAC

Through the **Dip Switch 4**, you can configure the output frequency.

SW4	HV mode	LV mode
off	50HZ	60HZ
on	60HZ	50HZ

Notice

Dip switch 5 was preserved without any function at present.

5.0 Control and Communication

5.1 Dry contact

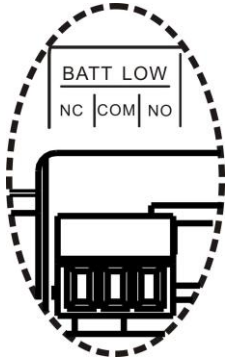

CPI has a built in dry contact. It will activate as soon as the battery voltage was detected dropping to threshold level which is 0.5VDC above the LVD level

The maximum contact load is:

230Vac /110Vac : 2A

12Vdc/24Vdc/48Vdc : 2A

5.2 RCC - Remote Control (optional)

Optional RCC – remote control could be purchased and connected to the CPI on central panel to have following functions:

- Load percentage
- Battery SOC: battery LED, from bottom to top representing 25%-50%-75%-100%
- Working status
- Alarm info
- Main switch: set your equipment at ON / OFF / PS mode

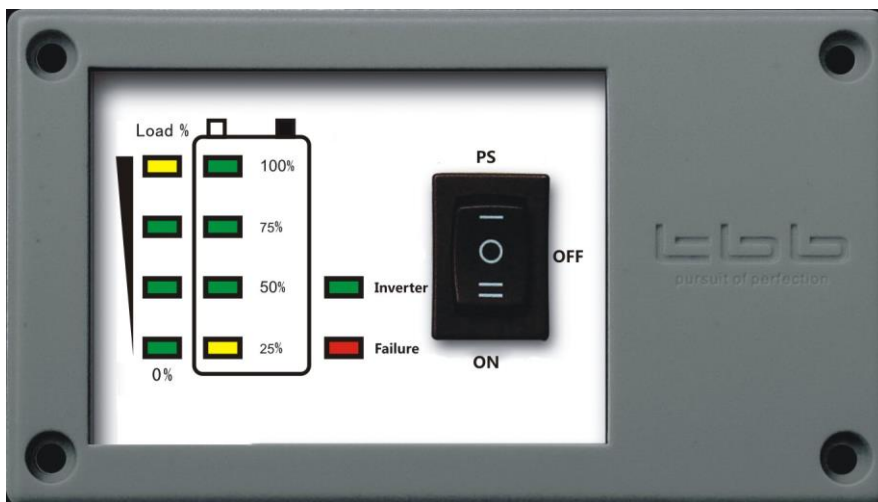

6.0 Installation

6.1 Material list

The unit is packed with following materials. Please confirm the series number on inverter is same to that on outer carton

- Equipment
- User's manual
- a Remote module (optional)

6.2 Location

Please install the equipment in a location of Dry, Clean, Cool with good ventilation.

- Working temperature : -10°C-50°C
- Storage temperature : -40-70°C
- Relative Humidity : 0%-95%, non-condensing
- Cooling : Forced air

6.3 Wiring recommendation

Please find the following minimum wire size. In case of DC cable longer than 1m, please increase the cross section of cable to reduce the loss.

System capacity	AC wiring		DC wiring		
	110VAC	220VAC	48VDC	24VDC	12VDC
600W	2.5mm ²	2.5mm ²	4mm ²	10mm ²	16mm ²
1KW	4mm ²	2.5mm ²	6mm ²	16mm ²	25mm ²
1.5KW	4mm ²	2.5mm ²	10mm ²	25mm ²	35mm ²
2KW	6mm ²	2.5mm ²	16mm ²	25mm ²	50mm ²
3KW	8mm ²	4mm ²	25mm ²	50mm ²	70mm ²
4KW	10mm ²	4mm ²	25mm ²	50mm ²	\
5KW	16mm ²	6mm ²	35mm ²	70mm ²	\
6KW	16mm ²	6mm ²	50mm ²	\	\

6.4 General advice

- Ensure that the inverter has the correct DC voltage with your existing battery system
- Install the CPI as close to the batteries as possible reducing the voltage drop on cable for the better performance of the equipment.



Do not connect the output of this equipment to your AC system at the same time as any other AC source such as the 230V external mains or a generator.

- We recommend connecting a DC fuse corresponding to the conductor between battery and CPI, which will offer protection to the battery cable.
- On the AC output side, we recommend connecting the output from the inverter to a suitable Residual Current Circuit Breaker and Circuit Breaker.

6.5 Installation and Connection



For the user operation safety, cut off the power before installation

6.5.1 Fix the equipment

- Basically, CPI could be installed either vertically on wall or horizontally on floor
- Please choose a flat surface and with 4XM6 to fix the unit securely
- Please find following installation dimension.

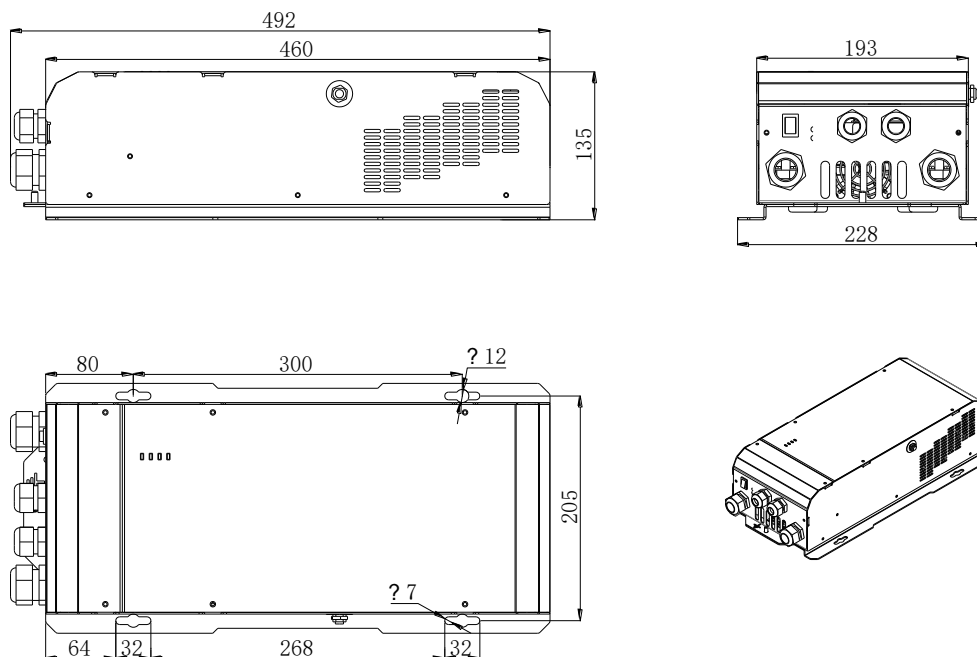

Frame A, for unit up to 1200W

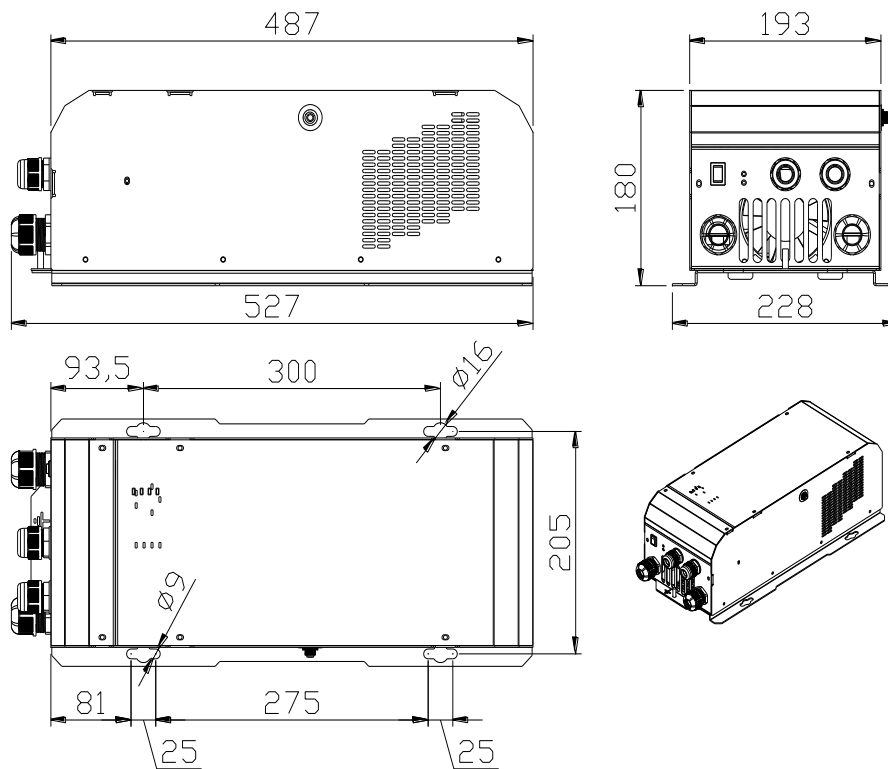

Frame B, for unit up to 3000W

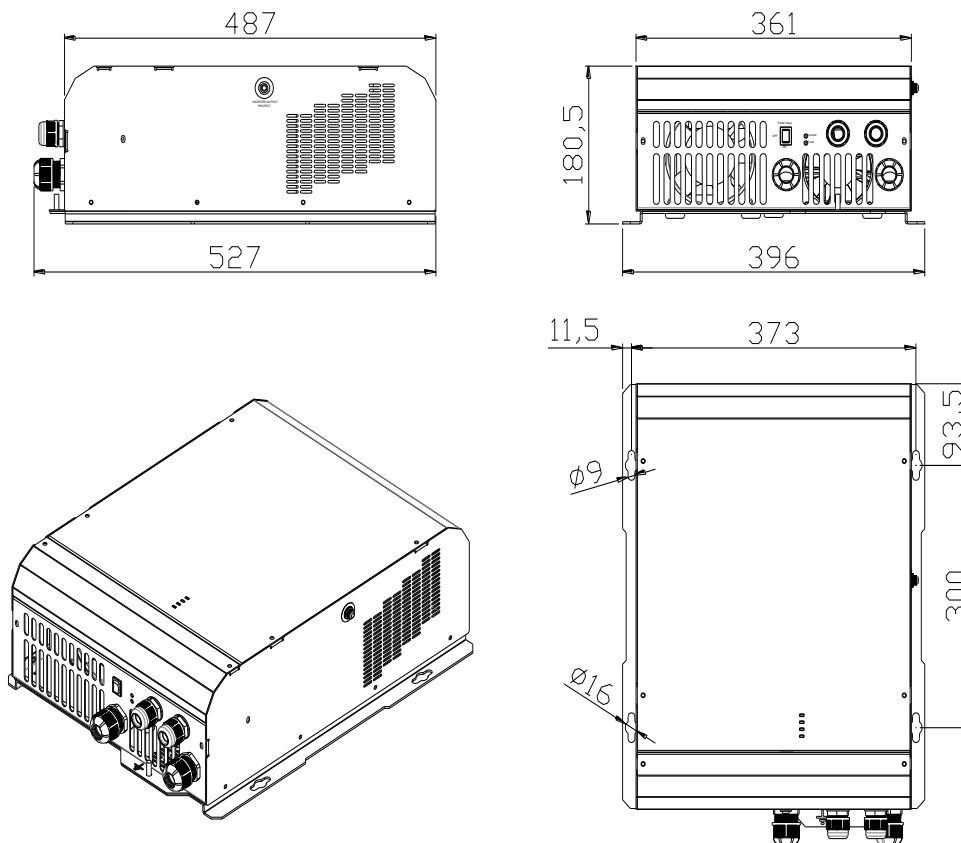

Frame C, for unit up to 6000W

6.5.2 Connecting the cable



Please make sure the CPI is turned off before connection. Otherwise, high voltage could be present.

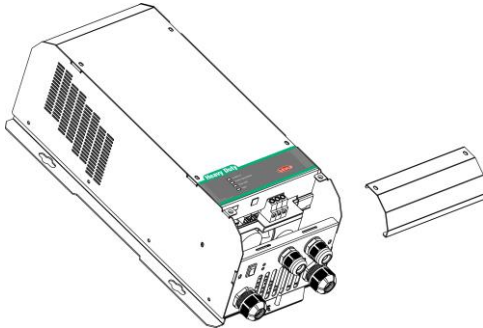

- Loose the screw and remove the top panel
- (if necessary) There is cable connecting the LED/switch of front panel to equipment, please plug out the connector at front panel. Then, loose the screw and remove the front panel

Connecting DC cable of service battery



Please double check battery voltage match the model you are going to installed, the wrong battery could destroy equipment and is out of warranty.



Please double confirm the polarity of DC input. Reverse polarity could cause permanent damage on equipment and it is out of warranty.

- Choose the right cable size (refer to 6.3) and follow polarity guide marked on the panel
- Pull through the DC cables through the holes at front panel, clamping the cable terminal on cable.
- Secure the battery cable on DC+ and DC- terminals respectively making sure it is tightly screwed

Connecting the AC cable

- AC output cable: choose the right cable size (refer to 6.3), pull through the AC output cable through Gland and connect it on AC output block. Connectors are marked as “L”-line, “N”-neutral and “PE”-earth. Making sure it is tightly screwed.



Please double check AC output was right after connection. Wrong connection will cause permanent damage of equipment and it is out of warranty.

- The neutral output of CPI is connected to earth once switch on.

Connecting the earth

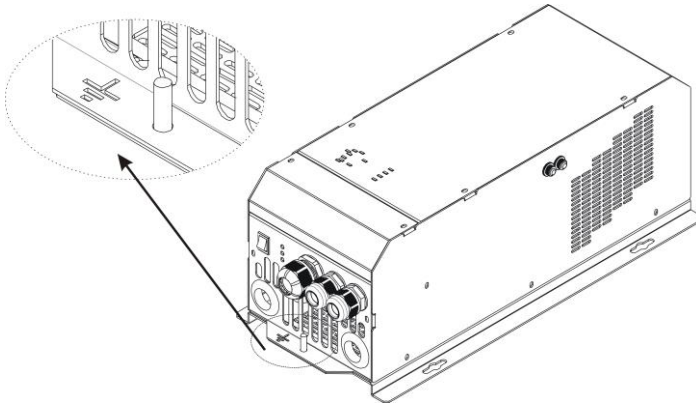

- At the front bottom of base, there is an earth connection point.
- Please connect it with EARTH by a proper gauge wire. (same wire gauge as you used connecting the AC output earth/PE)

6.5.3 Install the RCC - remote controller

The RCC was dash mounting design and can be hanged on wall too.

For dash mounting, please cut the hole according to following size and screw the remote controller securely through four screws at corners and connected the cables.

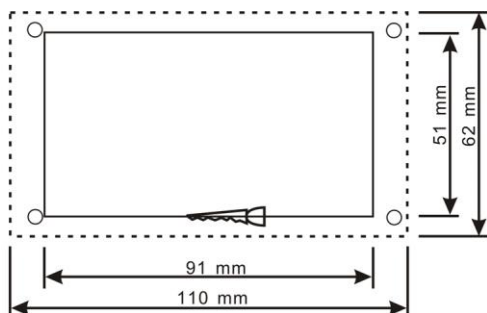

PIC A

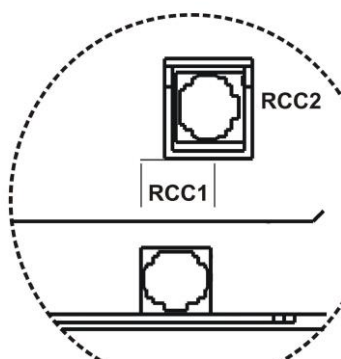
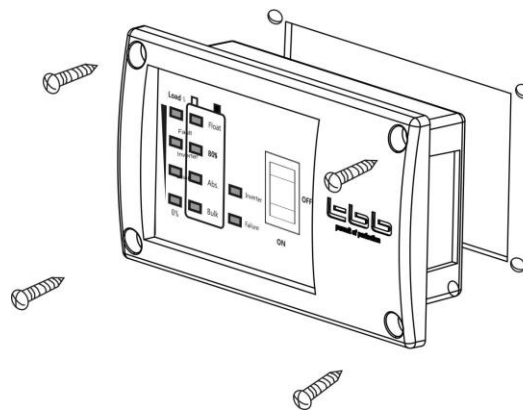

- Using the two cables supplied connecting the RCC to the port on the central panel. Please refer to left picture.
- RCC1 is a 6pin port and RCC2 is a 4pin port
- Pull through the cable through Gland and secure the installation afterwards.

7.0 Operation

7.1 Double Checking

- Check the DC input voltage of this inverter is same to your battery nominal voltage. NEVER try to connect different DC input to inverter.
- Inspect if you connect right polarity of DC with battery
- Inspect AC output connection is correct; make sure unit is no short cut.

7.2 Switch on the inverter

- Switching on the unit, the LED will all illuminate for analysis then there should be AC available at inverter output. The inverter LED will illuminate. You could switch on the load which will be powered by inverter.
- The Load % LED will reflect the load level connected.
- The SOC led will reflect the battery condition, which are 25%-50%-75%-100% respectively from bottom.

For detail system info, you can read out from top panel and remote panel

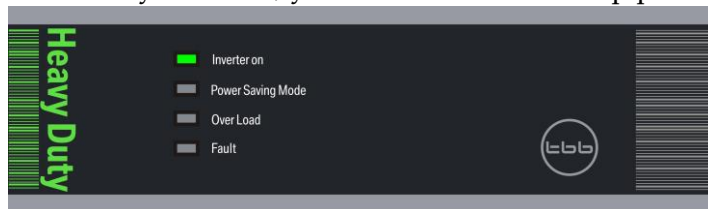

Top panel

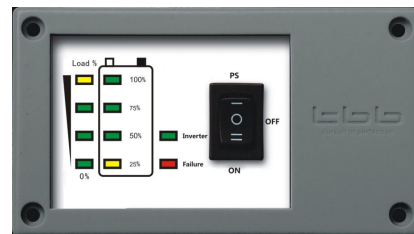

Remote

7.3 Power Saving mode

- You can set the CPI working in power save mode through the Main Switch either on inverter front panel or through RCC remote panel. It is marked PS
- Upon PS mode, Power Save mode LED on front panel will illuminate and the Inverter LED on RCC remote panel will flash.
- Under PS mode, the status consumption power can be dramatically reduced.

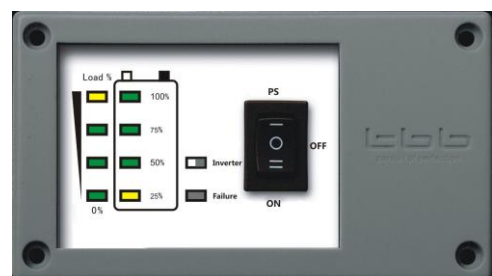
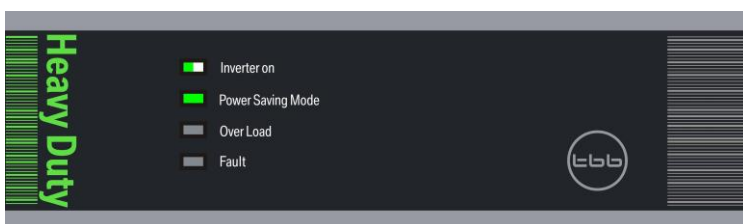

8.0 Trouble Shooting

√ : ON x : OFF

8.1 LED indicator and audible alarm on inverter

Status	Function	LED				Audible alarm
		Inverter	Power saving mode	Over load	Fault	
Inverter	Inverter ON	√	x	x	x	x
	Power Save mode	x	√	x	x	x
Alarm Mode	Battery low voltage	√	x	x	√	beep 0.5s every 5s
	Battery overvoltage	√	x	x	√	beep 0.5s every 1s
	Inverter overload	√	x	√	√	beep 0.5s every 1s
	Inverter overtemp	√	x	x	√	Beep 0.5s every 1s
Protection mode	Fan block	x	x	x	x	beep continuously
	Battery overvoltage	√	x	x	x	beep continuously
	Battery low voltage	x	x	x	x	
	Inverter overload	x	x	√	x	beep continuously
	overtemp	x	x	x	x	beep continuously
	Shortcut	x	x	x	x	beep continuously

8.2 LED indicator on RCC remote panel

Status	Function	LED on remote panel	
		Inverter	Fault
Inverter	Inverter ON	√	x
	Power Save mode	flash	x
Alarm Mode	Battery low voltage	√	√
	Battery overvoltage	√	√
	Inverter overload	√	√
	Inverter overtemp	√	√
Protection mode	Fan block	x	x
	Battery overvoltage	√	x
	Battery low voltage	x	x
	Inverter overload	x	x
	overtemp	x	x
	Shortcut	x	x

8.3 Percentage Bar on RCC remote panel

	percentage bar
Load BAR	from bottom to top representing 25%-50%-75%-100% load percentage of inverter
SOC BAR	from bottom to top representing 25%-50%-75%-100% of battery SOC

9.0 Specification

CPI HV mode Specification

Model No.	12Vdc	CPI1000L	CPI1200L	CPI1500L	CPI1800L	CPI2000L					
	24Vdc	CPI1000M	CPI1200M	CPI1500M	CPI1800M	CPI2000M	CPI3000M				
	48Vdc					CPI2000S	CPI3000S	CPI4000S	CPI5000S	CPI6000S	
Electrical											
Norminal Voltage	12Vdc, 24Vdc, 48Vdc										
Cont output power (40°C)	1000W	1200W	1500W	1800W	2000W	3000W	4000W	5000W	6000W		
Cosφ	0.9-1										
Overload Capability	>150%	20s									
	>125%	60s									
	>110%	15mins					1min				
Surge	300%										
Output voltage	208/220/230/240VAC ± 2%										
Output frequency	50/60Hz ± 0.1%										
Efficiency	12Vdc	89%									
	24Vdc	92%									
	48Vdc	94%									
Crest factor	.3:1										
THD	<3%										
Zero load power	12.5W	13W	14W	14.5W	15W	18W	26W	32W	36W		
Zero load power (power save mode)	3W	3.5W	3.5W	3.6W	3.75W	4.5W	6W	8W	9W		
Output circuit breaker	10A	10A	10A	15A	15A	30A	30A	30A	30A		
Overload and overheat protection	auto disconnect with 3 times restart attempt										
shortcut protection	auto disconnect										
Other Data											
Dry contact	Battery low										
Battery connector	M8 x 2										
Enclosure	Steel with powder paint										
Dimension (mm)	460x228x135			487x228x180				487x396x180			
Net Weight (kgs)	15	16	19	21	22	25	35	40	46		
Cooling	Forced fan										
Protection	IP21										
Standard											
Safety	EN60950-1										
Emmission	EN55022										
Immunity	EN55022										

CPI LV mode Specification

Model No.	12Vdc	CPI1000L-LV	CPI1200L-LV	CPI1500L-LV	CPI1800L-LV	CPI2000L-LV
	24Vdc	CPI1000M-LV	CPI1200M-LV	CPI1500M-LV	CPI1800M-LV	CPI2000M-LV
	48Vdc					CPI2000S-LV
Electrical						
Norminal Voltage		12Vdc, 24Vdc, 48Vdc				
Cont output power at (40°C)		1000W	1200W	1500W	1800W	2000W
Cosφ		0.9-1				
Overload Capability	>150%	20s				
	>125%	60s				
	>110%	15mins				
Surge		300%				
Output voltage		100/110/120/127VAC ± 2%				
Output frequency		50/60Hz ± 0.1%				
Efficiency	12Vdc	89%				
	24Vdc	92%				
	48Vdc	94%				
Crest factor		.3:1				
THD		<3%				
Zero load power		12.5W	13W	14W	14.5W	15W
Zero load power (power save mode)		3W	3.5W	3.5W	3.6W	3.75W
Output circuit breaker		10A	10A	10A	15A	15A
Overload and overheat protection		auto disconnect with 3 times restart attempt				
shortcut protection		auto disconnect				
Other Data						
Dry contact		Battery low				
Battery connector		M8 x 2				
Enclosure		Steel with powder paint				
Dimension (mm)		460x228x135			487x228x180	
Net Weight (kgs)		15	16	19	21	22
Cooling		Forced fan				
Protection		IP21				
Standard						
Safety		EN60950-1				
Emmission		EN55022				
Immunity		EN55022				