



DEEP CYCLE
SERIES: 5000
MODEL: 6 CS 21P

BATTERY ENGINEERING
WWW.ROLLSBATTERY.COM MADE IN CANADA

BATTERY TYPE: 6 VOLTS

DIMENSIONS:

LENGTH	559 MM	22	INCHES
WIDTH	248 MM	9 3/4	INCHES
HEIGHT	464 MM	18 1/4	INCHES

WEIGHTS:

WEIGHT DRY	98 KG	217 LBS.
WEIGHT WET	123 KG	271 LBS.

CONTAINER CONSTRUCTION:

CONTAINER: (INNER)	POLYPROPYLENE	TERMINALS:	FLAG WITH STAINLESS STEEL NUTS AND BOLTS
COVER: (INNER)	POLYPROPYLENE - HEAT SEALED TO INNER CONTAINER	HANDLES:	MOLDED
CONTAINER: (OUTER)	HIGH DENSITY POLYETHYLENE		
COVER: (OUTER)	HIGH DENSITY POLYETHYLENE SNAP FIT TO OUTER CONTAINER		

PLATES:

POSITIVE PLATE DIMENSION:

HEIGHT	273 MM	10.750	INCHES
WIDTH	143 MM	5.625	INCHES
THICKNESS	6.60 MM	0.260	INCHES

NEGATIVE PLATE DIMENSION:

HEIGHT	273 MM	10.750	INCHES
WIDTH	143 MM	5.625	INCHES
THICKNESS	4.57 MM	0.180	INCHES

CELLS: 3 **PLATES/CELL:** 21

POSITIVE PLATE ENVELOPED BY VERTICAL SLYVER GLASS MAT

SEPARATOR:
THICKNESS 3 MM 0.105 INCHES

INSULATION:
GLASS MAT 1 MM 0.020 INCHES

CAPACITY:

CRANK AMPS:		
COLD (CCA)	0°F / -17.8°C	1764
MARINE (MCA)	32°F / 0°C	2175

ELECTROLYTE RESERVE:
ABOVE PLATES 95 MM 3.75 INCHES

RESERVE CAPACITY:
RC @ 25A 1353 MINUTES

20 HR RATE: 683

	HOURLY RATE	SPECIFIC GRAVITY	CAP / AH	CURRENT / AMPS
CAPACITY @	100 HOUR RATE	1.280 SP. GR.	963	9.63
CAPACITY @	72 HOUR RATE	1.280 SP. GR.	908	12.62
CAPACITY @	50 HOUR RATE	1.280 SP. GR.	840	16.80
CAPACITY @	24 HOUR RATE	1.280 SP. GR.	710	29.6
CAPACITY @	20 HOUR RATE	1.280 SP. GR.	683	34.2
CAPACITY @	15 HOUR RATE	1.280 SP. GR.	635	42.3
CAPACITY @	12 HOUR RATE	1.280 SP. GR.	594	49.5
CAPACITY @	10 HOUR RATE	1.280 SP. GR.	567	56.7
CAPACITY @	8 HOUR RATE	1.280 SP. GR.	533	66.6
CAPACITY @	6 HOUR RATE	1.280 SP. GR.	485	80.8
CAPACITY @	5 HOUR RATE	1.280 SP. GR.	458	92
CAPACITY @	4 HOUR RATE	1.280 SP. GR.	423	106
CAPACITY @	3 HOUR RATE	1.280 SP. GR.	382	127
CAPACITY @	2 HOUR RATE	1.280 SP. GR.	328	164
CAPACITY @	1 HOUR RATE	1.280 SP. GR.	232	232



1 STATION RD SPRINGHILL, NOVA SCOTIA CANADA B0M 1X0 1.800.681.9914

REV.2
 Jan-10
 6 CS 21P

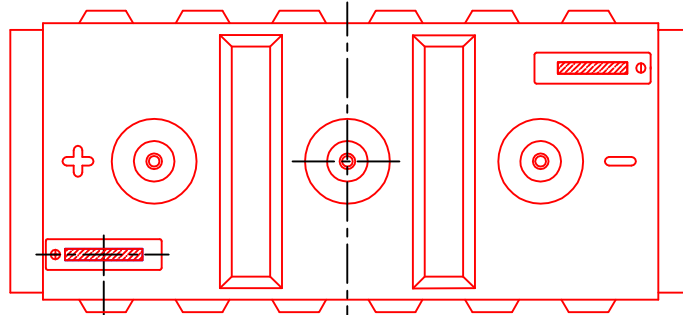

PART NUMBER: 6-CS-21P
 WEIGHT WET: 271 LB / 123 KG
 WEIGHT DRY: 217 LB / 98 KG
 CAPACITY: 683 AH 20 HR
 VOLTAGE: 6 V
 OVERALL DIMENSIONS: 22" X 9 3/4" X 18 1/4"
 MAX HEIGHT WITH OPTIONAL HYDROCAPS: 18 5/8" - 473 MM

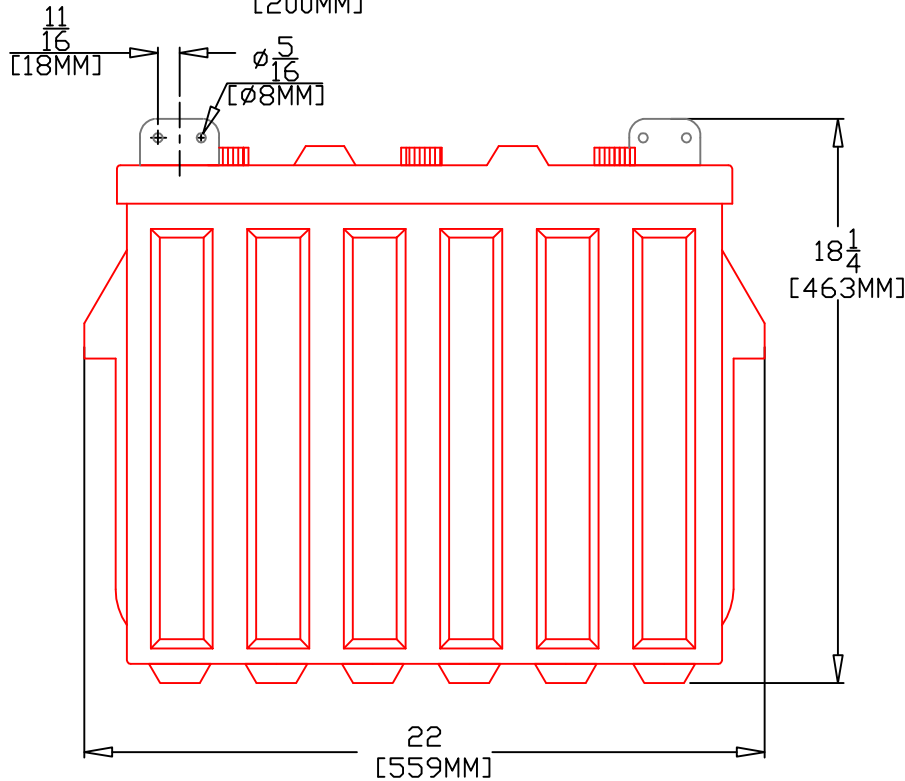
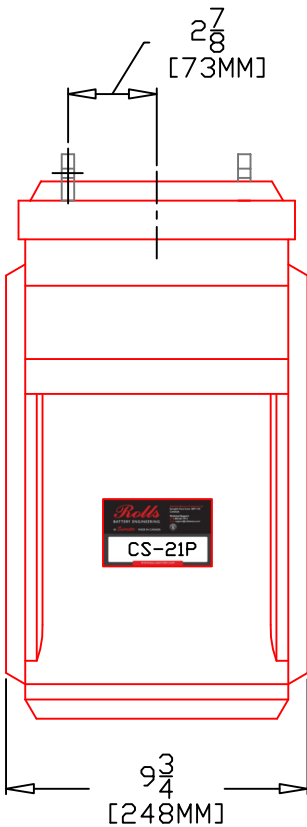

TITLE:	6CS21P
DESCRIPTION:	6V / 3 CELL 21 PLATE (CS) DEEP CYCLE 500/5000 SERIES
CONTACT INFO:	WEB: WWW.ROLLSBATTERY.COM E-MAIL: SALES@ROLLSBATTERY.COM PHONE: 1-800-681-9914
SCALE:	1" = 6" 8.5" X 11" 1" = 4" 11" X 17" JPEG NOT TO SCALE
Drawn by:	Approved By:
S. WILES	D. SURRETTE
DATE: JAN-2010	REVISION 2.0
DRAWING NO.: DWG 006, BD6CS21P	