



**DEEP CYCLE**  
**SERIES: 5000**  
**MODEL: 6 CS 17P**

**BATTERY ENGINEERING**  
**WWW.ROLLSBATTERY.COM MADE IN CANADA**

**BATTERY TYPE: 6 VOLTS**

**DIMENSIONS:**

**LENGTH** 559 MM 22 INCHES  
**WIDTH** 210 MM 8 1/4 INCHES  
**HEIGHT** 464 MM 18 1/4 INCHES

**WEIGHTS:**

**WEIGHT DRY** 81 KG 178 LBS.  
**WEIGHT WET** 100 KG 221 LBS.

**CONTAINER CONSTRUCTION:**

**CONTAINER: (INNER)** POLYPROPYLENE **TERMINALS:** FLAG WITH STAINLESS STEEL NUTS AND BOLTS  
**COVER: (INNER)** POLYPROPYLENE - HEAT SEALED TO INNER CONTAINER  
**CONTAINER: (OUTER)** HIGH DENSITY POLYETHYLENE **HANDLES:** MOLDED  
**COVER: (OUTER)** HIGH DENSITY POLYETHYLENE SNAP FIT TO OUTER CONTAINER

**PLATES:**

**POSITIVE PLATE DIMENSION:**  
**HEIGHT** 273 MM 10.750 INCHES  
**WIDTH** 143 MM 5.625 INCHES  
**THICKNESS** 6.73 MM 0.265 INCHES

**NEGATIVE PLATE DIMENSION:**  
**HEIGHT** 273 MM 10.750 INCHES  
**WIDTH** 143 MM 5.625 INCHES  
**THICKNESS** 4.70 MM 0.185 INCHES

**CELLS:** 3 **PLATES/CELL:** 17

POSITIVE PLATE ENVELOPED BY VERTICAL SLYVER GLASS MAT

**SEPARATOR:**  
**THICKNESS** 3 MM 0.105 INCHES

**INSULATION:**  
**GLASS MAT** 1 MM 0.020 INCHES

**CAPACITY:**

**CRANK AMPS:**  
**COLD (CCA)** 0°F / -17.8°C 1357  
**MARINE (MCA)** 32°F / 0°C 1696

**ELECTROLYTE RESERVE:**  
**ABOVE PLATES** 76 MM 3 INCHES

**RESERVE CAPACITY:**  
**RC @ 25A** 1083 MINUTES

**20 HR RATE: 546**

	<b>HOURLY RATE</b>	<b>SPECIFIC GRAVITY</b>	<b>CAP / AH</b>	<b>CURRENT / AMPS</b>
CAPACITY @	100 HOUR RATE	1.280 SP. GR.	770	7.70
CAPACITY @	72 HOUR RATE	1.280 SP. GR.	726	10.09
CAPACITY @	50 HOUR RATE	1.280 SP. GR.	672	13.43
CAPACITY @	24 HOUR RATE	1.280 SP. GR.	568	23.7
<b>CAPACITY @</b>	<b>20 HOUR RATE</b>	<b>1.280 SP. GR.</b>	<b>546</b>	<b>27.3</b>
CAPACITY @	15 HOUR RATE	1.280 SP. GR.	508	33.9
CAPACITY @	12 HOUR RATE	1.280 SP. GR.	475	39.6
CAPACITY @	10 HOUR RATE	1.280 SP. GR.	453	45.3
CAPACITY @	8 HOUR RATE	1.280 SP. GR.	426	53.2
CAPACITY @	6 HOUR RATE	1.280 SP. GR.	388	64.6
CAPACITY @	5 HOUR RATE	1.280 SP. GR.	366	73
CAPACITY @	4 HOUR RATE	1.280 SP. GR.	339	85
CAPACITY @	3 HOUR RATE	1.280 SP. GR.	306	102
CAPACITY @	2 HOUR RATE	1.280 SP. GR.	262	131
CAPACITY @	1 HOUR RATE	1.280 SP. GR.	186	186



1 STATION RD SPRINGHILL, NOVA SCOTIA CANADA B0M 1X0 1.800.681.9914

REV.2  
 Jan-10  
 6 CS 17P

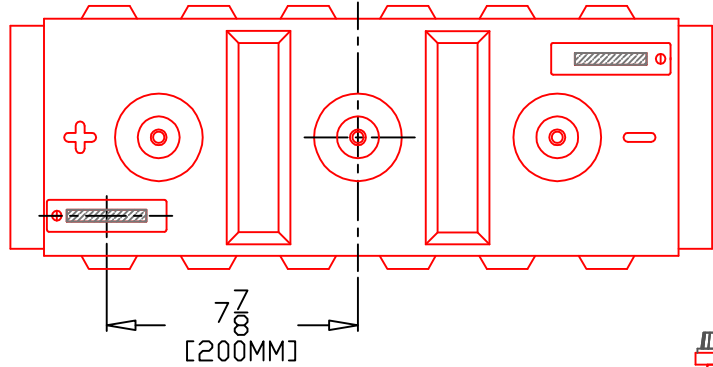

PART NUMBER: 6-CS-17P  
 WEIGHT WET: 221 LB / 100 KG  
 WEIGHT DRY: 178 LB / 81 KG  
 CAPACITY: 546 AH 20 HR  
 VOLTAGE: 6 V  
 OVERALL DIMENSIONS: 22" X 8 1/4" X 18 1/4"  
 MAX HEIGHT WITH OPTIONAL HYDROCAPS: 18 5/8" - 473 MM

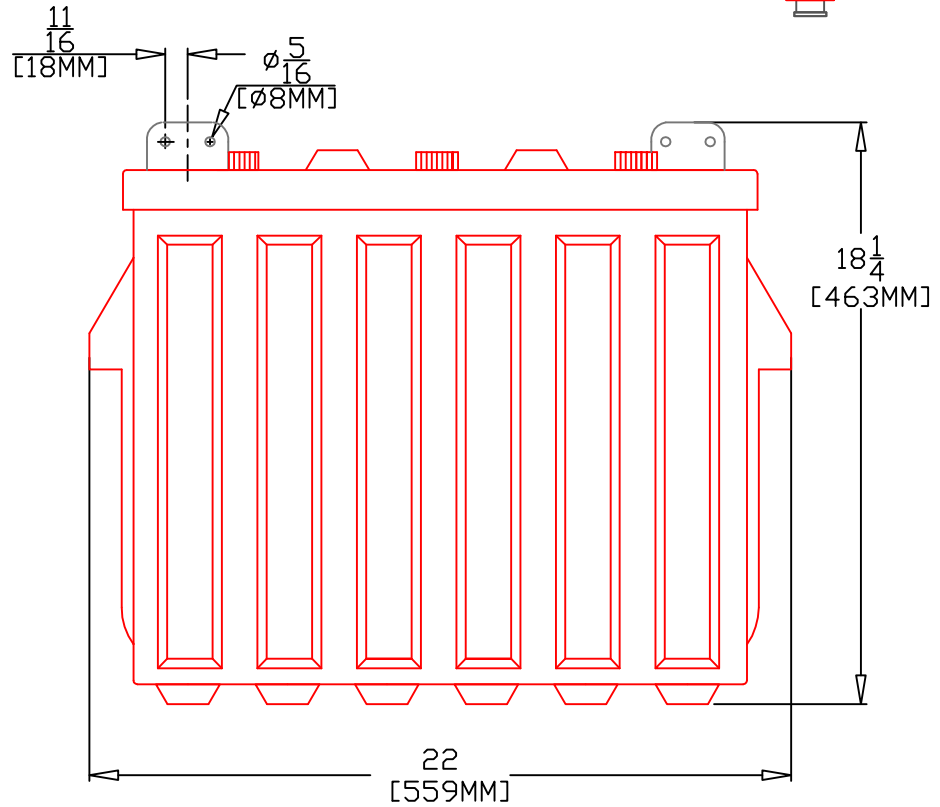
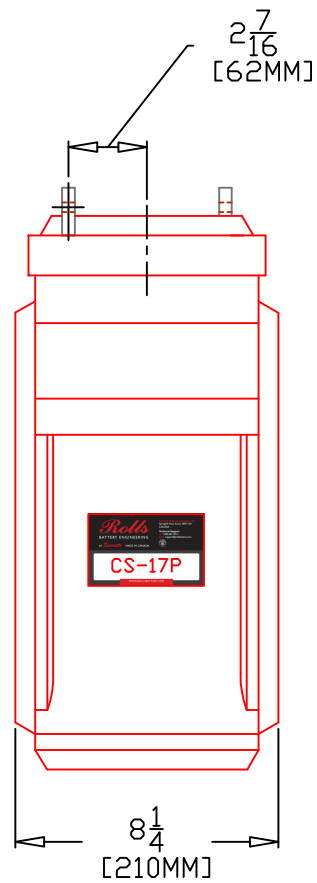

TITLE:	6CS17P
DESCRIPTION:	6V / 3 CELL 17 PLATE (CS) DEEP CYCLE
CONTACT INFO:	WEB: WWW.ROLLSBATTERY.COM E-MAIL: SALES@ROLLSBATTERY.COM PHONE: 1-800-681-9914
SCALE:	1" = 6" 1" = 4" JPEG 8.5" X 11" 11" X 17" NOT TO SCALE
Drawn by:	Approved By:
S. WILES	D. SURRETTE
DATE:	REVISION
JAN-2010	2.0
DRAWING NO.:	DWG 005, BD6CS17P