

# BP12-7.0(12V7.0AH)

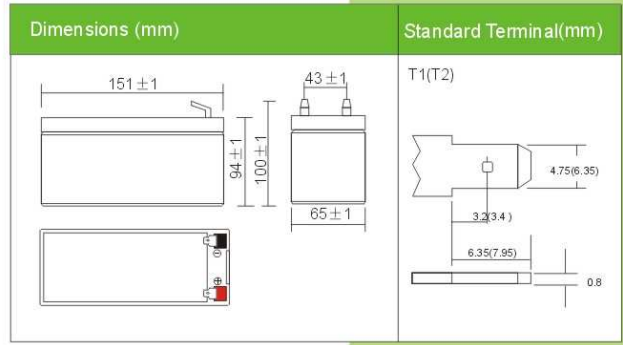

PHYSICAL SPECIFICATION		
Nominal Voltage		12V
Nominal Capacity (20HR)		7.0AH
Dimension	Length	151±1mm (5.94 inches)
	Width	65±1mm (2.56 inches)
	Container Height	94±1mm (3.72 inches)
	Total Height (with Terminal)	100±1mm (3.94 inches)
Weight		Approx 2.45kg (5.40lbs)
Standard Terminal		T1/T2(standard)

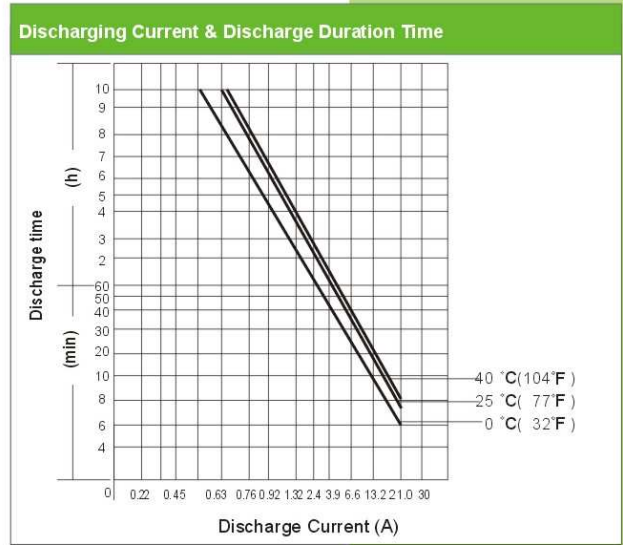

ELECTRICAL SPECIFICATION					
Rated Capacity	20 hour rate (350mA)	7.00AH	Constant-Voltage Charge	Cycle	Initial Charging Current less than 2.1A. Voltage 14.4V~15.0V at 25°C (77°F) Temp. Coefficient -30mV/°C
	10 hour rate (651mA)	6.51AH			
	5 hour rate (1.19 A)	5.95AH			
	1 hour rate (3.85A)	4.34AH			
	15minute rate (12.78A)	3.20AH			
Capacity affected by Temperature	40°C (104°F)	103%	Standby	No limit on Initial Charging Current Voltage 13.5V~13.8V at 25°C(77°F) Temp. Coefficient -20mV/°C	
	25°C (77°F)	100%			
	0°C (32°F)	86%			

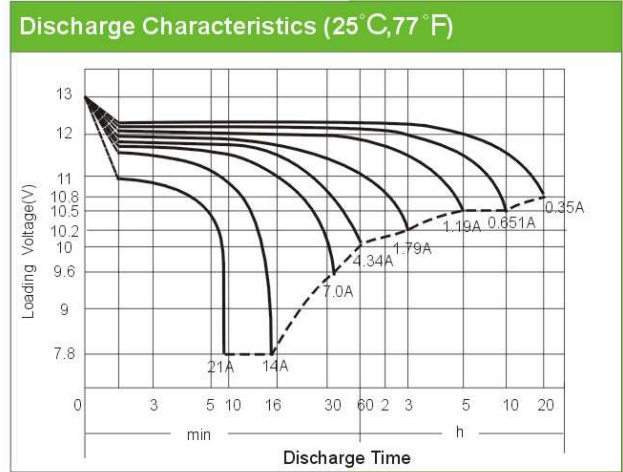

### Constant Current (Amp) and Constant Power (Watt) Discharge Table (25°C, 77°F)

Time(minute) Final voltage/Cell	Amp/Watt/Cell											
	5	10	15	20	30	45	60	120	180	300	600	1200
A	27.44	17.60	12.78	9.88	7.89	5.60	4.34	2.45	1.79	1.19	0.651	0.35
W	49.12	33.09	24.31	19.32	15.50	11.13	8.61	4.87	3.55	2.38	1.26	0.70